

piSAVE release



piSAVE release

- Equalizes pressure in the suction cups to provide fast release of the product.
- Extra fast release by accumulating and utilizing the feed-air pressure as a boost.
- ON/OFF activated simultaneously with the ejector.
- No additional controls required — use a single 3/2 control valve for the ejector and piSAVE release.

Technical data

Description	Unit	Value
Feed pressure, range	psi	44–87
Material		Al, SS, NBR
Temperature range	°F	32–122
Weight	oz	1.66
Connection, compressed air		G1/8"
Dimension, WxDxH	in	1.02x1.02x1.47

Technical data, specific

Description	Unit	Value	
		01.19.721	01.19.720
Connection, vacuum		G1/8"	G1/4"
Flow, atmospheric	scfm	3.85	7.85

Ordering information

	Description	Part No.
A	piSAVE release G1/8"	01.19.721
B	piSAVE release G1/4"	01.19.720

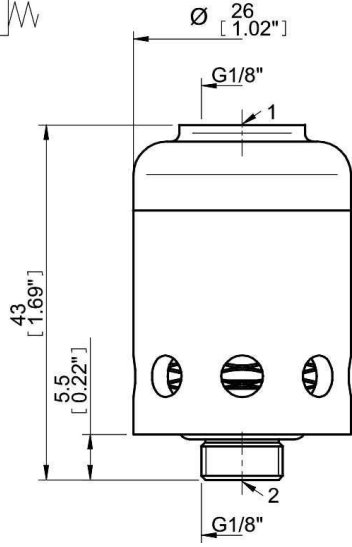
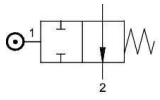

A

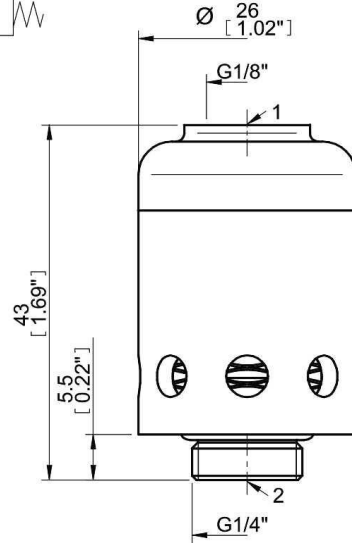
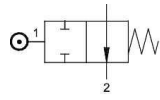

B